

Operator: Save these instructions for future use!

**FAILURE TO READ AND FOLLOW ALL INSTRUCTIONS CAREFULLY BEFORE
INSTALLING OR OPERATING THIS CONTROL COULD CAUSE PERSONAL
INJURY AND/OR PROPERTY DAMAGE.**

DESCRIPTION

The 36C/36D series HSI, DSI proven pilot gas valves are for use on Spark or Hot Surface Ignition systems and replaces many O.E.M. gas valves. These valves may be mounted in any position except upside down. Inlet screen and pilot gas filter provide maximum protection against chips and dirt. ON/OFF switch and regulator adjustment (on some models) are on top of valve for quick setup. Large, easy-grip pipe boss speeds installation.

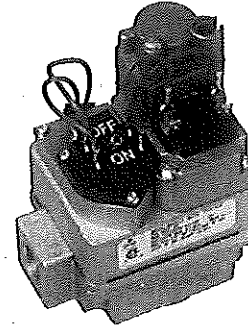

UNIVERSAL ELECTRONIC IGNITION GAS VALVES One Model Fits Most Applications

Model Number	Coil Voltage	Gas Type	Pipe Size	Opening Characteristic	Regulator Setting	Regulator Adjustment Range	Convertible Nat./LP	LP Conversion Kit Included	Line Interrupter	Flow Direction	Reducer Bushing Kit	Inlet Pressure Tap	Side Taps	Internal Wiring See Figure ①
36C68-923	24 VAC	Natural	3/4 x 3/4	Fast Open	3.5"	2.5"-5.0"	Yes	Yes	No	Str. Thru	Yes	No	No	3

Model Number	Coil Voltage	Gas Type	Pipe Size	Opening Characteristic	Regulator Setting	Regulator Adjustment Range	Convertible Nat./LP	LP Conversion Kit Included	Line Interrupter	Flow Direction	Reducer Bushing Kit	Inlet Pressure Tap	Side Taps	Internal Wiring See Figure ①
36C74-913	24 VAC	Natural	3/4 x 3/4	Step	0.9"/3.5"	2.5"-5.0"	No	No	No	Str. Thru	Yes	Yes	No	3
36C76-906	24 VAC	Natural	3/4 x 3/4	2 Stage Bimetal, Electric Open	1.0"/3.5"	2.5"-5.0"	No	No	No	Str. Thru	No	Yes	No	5
36C76-920	24 VAC	Natural	3/4 x 3/4	2 Stage Bimetal, Electric Open	1.3"/3.5"	2.5"-5.0"	No	No	No	Str. Thru	No	Yes	No	5
36C76-962	24 VAC	LP	3/4 x 3/4	2 Stage Bimetal, Electric Open	5.0"/11.0"	9.0"-12.0"	No	No	No	Str. Thru	No	No	No	5
36C76-963	24 VAC	Natural	3/4 x 3/4	2 Stage Bimetal, Electric Open	2.0"/3.5"	2.5"-5.0"	No	No	No	Str. Thru	Yes	Yes	No	5
36D13-508	24 VAC	Natural	1/2 x 1/2	2 Stage Relay, Electric Open	1.1"/3.5"	Non-Adjustable	No	No	No	Str. Thru	No	No	No	6
36D13-905	24 VAC	Natural	3/4 x 3/4	2 Stage Relay, Electric Open	1.1"/3.5"	2.5"-5.0"	No	No	No	Str. Thru	No	No	No	6
36D13-914	24 VAC	LP	3/4 x 3/4	2 Stage Relay, Electric Open	2.5"/11.0"	Non-Adjustable	No	No	No	Str. Thru	No	No	No	6

* Indicates Canadian Model Number

① Wiring diagrams – see pages 4 & 5

PRECAUTIONS

DO NOT BEGIN INSTALLATION UNTIL YOU READ THE FOLLOWING PRECAUTIONS.

⚠ WARNING



If you do not follow these instructions exactly, a fire or explosion may result causing property damage, personal injury or loss of life.

1. Failure to turn off electric or main gas supply to heating system could cause personal injury and/or property damage by shock, gas suffocation, fire, and/or explosion.
2. Do not use this control on circuits exceeding specified voltage. Higher voltage will damage the control and may cause shock or fire hazard.
3. NEVER USE FLAME OR ANY KIND OF SPARK TO CHECK FOR GAS LEAKS—COULD CAUSE FIRE AND/OR EXPLOSION.
4. Do not use a control set for natural gas with LP gas, or a control set for LP gas with natural gas. Personal injury and/or property damage, gas suffocation, fire, and/or explosion may result.

⚠ CAUTION

1. Do not short out terminals on gas valve or primary control to test. Short or incorrect wiring can cause equipment damage, property damage and/or personal injury.
2. This control is not intended for use in locations where it may come in direct contact with water. Suitable protection must be provided to shield the control from exposure to water (dripping, spraying, rain, etc.).

SPECIFICATIONS

Electrical Rating: 0.6 amps

End to End Dimensions: 3¹⁵/₁₆"

Ambient Operating Range: -40 to +175°F (-40 to 79°C)

Maximum Pressure Rating: 1/2 PSI (14.0" W.C.)

Agency: A.G.A. and C.G.A. design certified

Pipe Size	1" Pressure Drop Capacity		Rated Range of Regulation	
	BTU/HR		BTU/HR	
	AGA STD. NAT GAS 1000 BTU/CU. FT.	LP GAS 2500 BTU/CU. FT.	AGA STD. NAT GAS 1000 BTU/CU. FT.	LP GAS 2500 BTU/CU. FT.
1/2 X 3/8	100,000	162,000	15,000-100,000	15,000-162,000
1/2 X 1/2	230,000	372,600	30,000-290,000	30,000-469,000
1/2 X 3/4	230,000	372,600	30,000-290,000	30,000-469,000
3/4 X 3/4	280,000	453,600	50,000-400,000	50,000-648,000

MAIN PIPING CONNECTIONS

NOTE

All piping must comply with local codes, ordinances, and/or national fuel gas codes.

1. Turn off electrical power to the system at the fuse box or circuit breaker. Also turn off the main gas supply.
2. If replacing an existing valve, disconnect all plumbing and electrical connections from the old control.
3. The valve may be installed in any position **except upside down**. The arrow on the bottom plate indicates the direction of gas flow through the valve. See page 3.
4. You should use new pipe that is properly chamfered, reamed, and free of burrs and chips. If you are using old pipe, be sure it is clean and free of rust, scale, burrs, chips, and old pipe joint compound.
5. Apply pipe joint compound (pipe dope) or teflon tape **that is approved for all gases, only to the male threads of the pipe joints. DO NOT** apply compound or teflon tape to the first two threads.
6. If you are using a vise or open-end wrench to hold the valve while installing piping, do not tighten excessively, as this may damage the valve.
7. See wiring pages 4 and 5 when making electrical connections.

After all gas and electrical connections are completed, turn gas on and check for gas leaks with leak detection solution or soap suds. Bubbles forming indicate a leak.
SHUT OFF GAS AND FIX ALL LEAKS IMMEDIATELY.

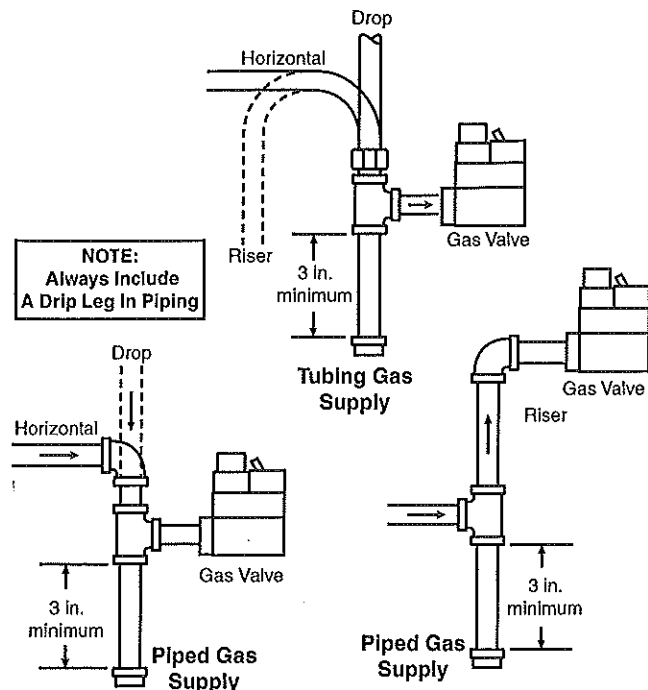
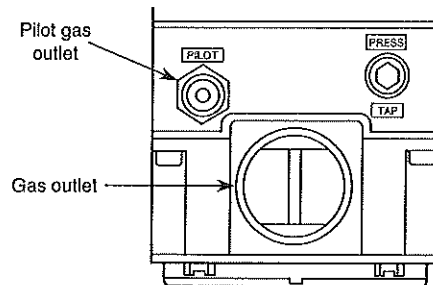

Figure 1. Typical gas valve piping

PILOT GAS CONNECTION

The valve is shipped with the pilot outlet plugged. For installations requiring pilot gas, remove the plug and use the fitting packed separately with the control.

Install fitting into pilot gas outlet turning until finger-tight. Insert clean, deburred tubing all the way through the fitting. While holding the tubing securely, slowly tighten fitting until you feel a slight "give". Tighten the fitting an additional 1½ turns.



Gas valve side view

Upright, 90° from upright or vertical

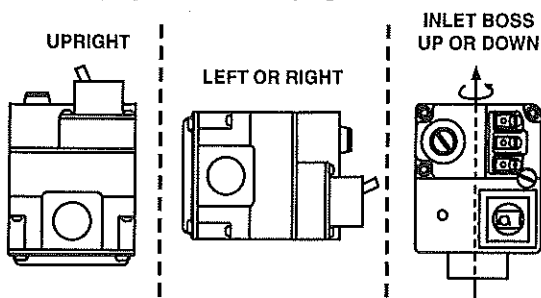

NOTE: Control shown may not be identical to replacement control.

Figure 2. Mounting positions

WIRING DIAGRAMS

SYSTEM WIRING

REFER TO AND FOLLOW THE APPLIANCE MANUFACTURER'S WIRING DIAGRAM. USE THE TABLE ON PAGE 1 TO IDENTIFY THE PROPER TERMINAL IDENTIFICATION FIGURE FOR THE GAS VALVE.

NOTE

All wiring should be installed in accordance with local and national electrical codes and ordinances.

Always check that the electrical power supply used agrees with the voltage and frequency shown on the gas control.

Wiring for 36C68-923 & 36C74-913 Gas Valves

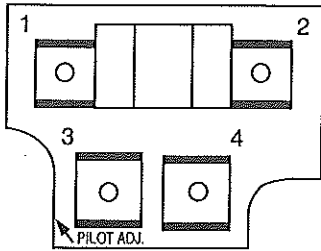
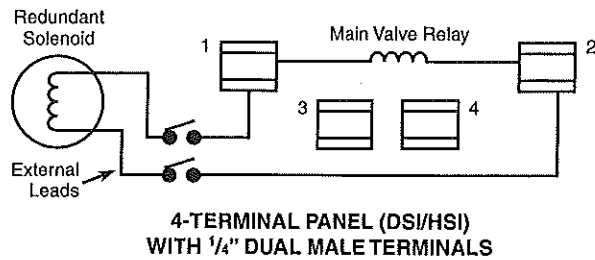
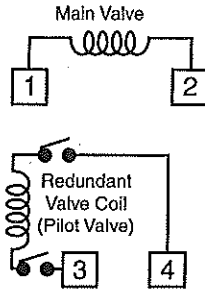
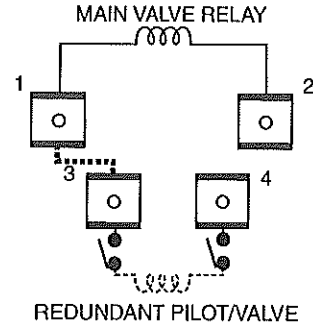

Figure 3
4 terminal panel



Wiring for 36C76-920 & 36C76-962, -963 Gas Valves

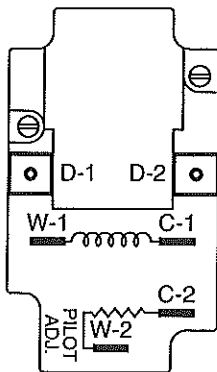
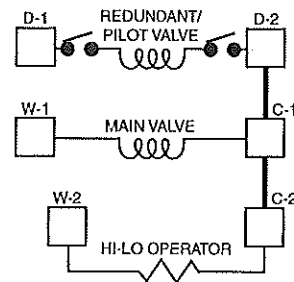

Figure 4
Bi-metal two stage



Wiring for 36C76-906 Gas Valve

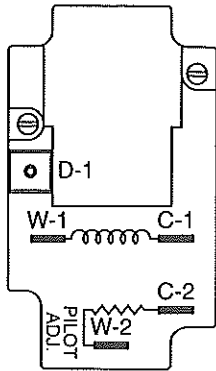
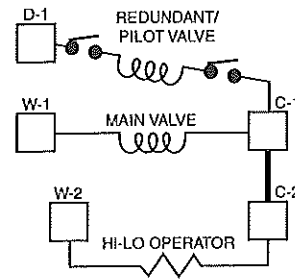

Figure 5
Bi-metal two stage



Wiring for 36D13-508, -905, & -914 Gas Valves

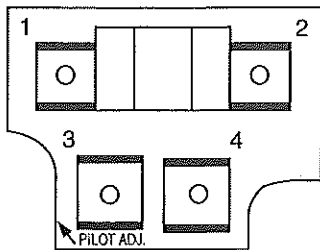
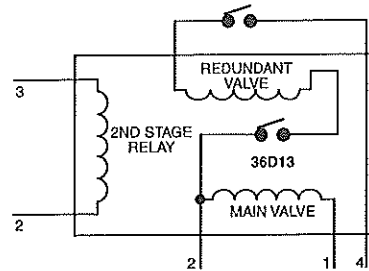

Figure 6
Relay two stage



INSTALLATION (cont'd)

Outlet Pressure Adjustments

These controls are shipped from the factory with the regulator set to the outlet pressure shown in the table on page 1. Consult the appliance rating plate and set the outlet pressure to match the appliance manufacturers specifications.

Conversion from Natural Gas to L.P.

1. Remove regulator cover screw.
2. Turn regulator adjustment screw counterclockwise and remove from valve.
3. Remove regulator spring from valve.
4. Insert proper spring Nat./L.P. into the valve.
5. Replace the regulator adjustment screw and adjust to appliance manufacturers specifications.
6. Replace regulator cover screw.

Model	Conversion from Natural/LP	Pilot Gas Adjustment	Outlet Pressure Regulator Adjustment
36C68-923	See Conversion from Natural Gas to L.P.	See Fig. 7	See Fig. 7
36C74-913	Not Convertable	See Fig. 7	See Fig. 8
36C76-906	Not Convertable	See Fig. 7	See Fig. 7
36C76-920	Not Convertable	See Fig. 7	See Fig. 7
36C76-962	Not Convertable	See Fig. 7	See Fig. 7
36C76-963	Not Convertable	See Fig. 7	See Fig. 7
36D13-508	Not Convertable	See Fig. 7	See Fig. 7
36D13-905	Not Convertable	See Fig. 7	See Fig. 7
36D13-914	Not Convertable	See Fig. 7	Non-Adjustable

OUTLET PRESSURE REGULATOR ADJUSTMENT FOR VALVES WITH AN ADJUSTABLE REGULATION RANGE

The pressure regulator has been factory adjusted (see control for specific setting). Although additional adjustments will not normally be necessary, you may adjust the regulator. **Do not force the adjusting screw beyond the limits that it can easily be adjusted.**

1. Energize system to ignite main burner.
2. Remove "Reg. Adj." cover screw.
3. To **DECREASE** outlet pressure, turn the adjusting screw (beneath the cover screw) counterclockwise. To **INCREASE** outlet pressure, turn the adjusting screw clockwise.
4. Replace the cover screw. Cycle the valve two or three times to verify regulator setting.

PILOT GAS ADJUSTMENT

This control was factory preset and will not normally require additional adjustment of pilot flame.

If the pilot flame is low and does not engulf the bulb of the sensor, the system will not energize the main valve.

If pilot gas pressure is too high, gas will sputter past the ignition electrode, and may not ignite. High pilot gas pressure may also cause the flame to lift off the burner, causing the flame sensor bulb to sense "low" heat.

To adjust the pilot flame, remove the cover screw and gasket (see fig. 7). To **REDUCE** pilot flame, turn the pilot adjust screw (beneath the cover screw) clockwise. To **INCREASE** pilot flame, turn the pilot adjust screw counterclockwise. Replace gasket and tighten cover screw.

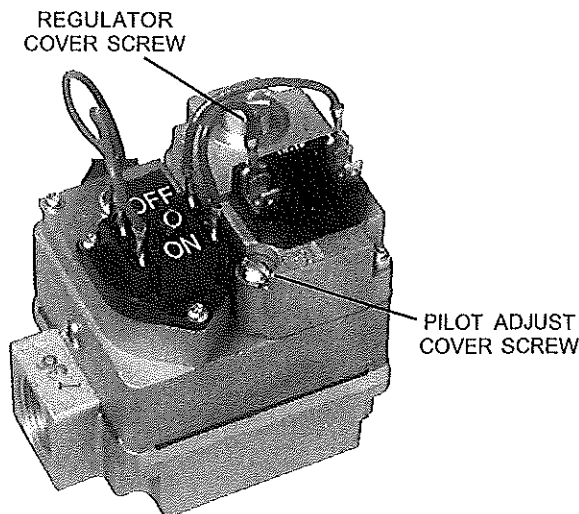

Figure 7. Adjustable regulator range

ADJUSTABLE REGULATION RANGE FOR 36C74-913

The pressure regulator has been factory adjusted for 3.5" W.C. (Natural Gas, full flow) or 11.0 W.C. (LP Gas, full flow). Although additional adjustments will not normally be necessary, the regulator may be adjusted if required. **Do not force the adjusting screw beyond the limits that it can easily be adjusted.**

1. Attach a manometer to the outlet pressure tap of the valve.
2. Energize valve to ignite main burner.
3. Remove "Reg. Adj." cover screw.
4. To **DECREASE** outlet pressure, turn the adjusting screw (beneath the cover screw) counterclockwise. To **INCREASE** outlet pressure, turn the adjusting screw clockwise.
5. Replace the cover screw. Cycle the valve two or three times to verify regulator setting.

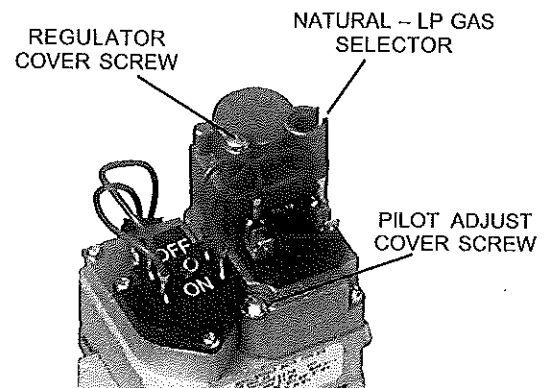

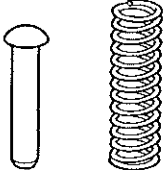

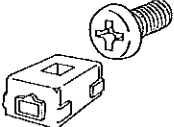
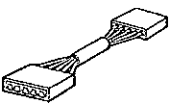
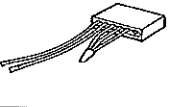
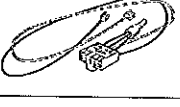

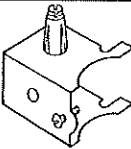
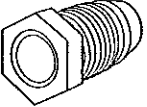
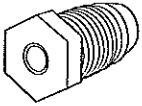



Figure 8. Gas valve top

PARTS & ACCESSORIES

Item Number	Model Number	Description
	F92-0656	L.P. to natural gas conversion kit for 36C, 36D, 36E and 36F gas valves with regulation range of 2.5 to 5" W.C.
	F92-0659	Natural to regulated L.P. gas conversion kit for 36C, 36D, 36E and 36F gas valves with regulation range of 7.5 to 12.0" W.C.
	F92-0737	Natural to unregulated L.P. gas conversion kit for 36C gas valves.
	F92-0866	Conversion kit for 36C gas valves with regulation range of 4.2 to 11.0" W.C.
	F92-0773	Adapter bracket for remote rod adjustment of A-cock on older 36C type gas valves. Not for new style knob pictured in this catalog.
	F115-0059	36" replacement harness assembly for connection of 50A22-201 to 36C84-426 in the 21D18-5 Cycle-Pilot® retrofit kit or to 36C84-436 in the 21D18-15.
	F115-0064	36" replacement harness assembly for connection of 5059-23 to 36C84-426 in the 21D18-3 Cycle-Pilot® retrofit kit.
	F115-0087	36" replacement harness assembly for connection of 5059-23 to 36E86-302 in the 21D18-14 Cycle-Pilot® retrofit kit.
	F115-0100	Harness assembly for HSI systems with 36E gas valves; connects the 767A Ignitor with the 50E47 or the 50F47 ignition module.

Item Number	Model Number	Description
	F6-1794	Bracket for Bryant pilots when retrofitting with Cycle-Pilot®.
	F69-0727	1/4" brass compression fitting for pilot line connections.
	F69-1988	Brass compression fitting adapter for 1/8" pilot line connections. 7/16"-24 thread.
	F92-0514	Reducer bushings for 36C and 36E gas valves. Contains one 3/4" x 1/2" N.P.T. and one 3/8" x 1/2" N.P.T.